

## Contact Details

Before using the product, please check the guide pages at the front of this catalog.

Internet

<https://www.daikinpmc.com/en/>

For latest information, PDF catalogs and operation manuals

# Direct Operated Relief Valve (for Remote Control)



JIS graphic symbols for hydraulic system

See appendix table 1.

## Features

- These valves are stacked together with solenoids to remotely control the pressure by connecting to the vent port of pilot operated pressure control valves such as relief valves and reducing valves.
- They allow free selection of multiple pressure control (up to triple pressure control) by switching the solenoid.
- The stack installation system conforming to ISO 4401 substantially reduces the installation space and eliminates complicated piping and manifold blocks.

## Nomenclature

⊗ - MRV - ⊗ ⊗ - ⊗ ⊗ ⊗ - 10  
 1 2 3 4 5 6 7 8

### 1 Applicable fluid code

No designation: Petroleum-based hydraulic fluid, water-glycol hydraulic fluid

F: Phosphate ester hydraulic fluid

### 2 Model No.

MRV: Direct operated relief valve (stack type)

### 3 Number of built-in relief valves (See appendix table 1)

S: 1

W: 2

T: 3

### 4 Number of built-in relief valve control ports (See appendix table 1)

### 5 6 7 Pressure control system and pressure adjustment range (See appendix table 3)

Specify the number from among 1 to 6 given in appendix table 3.

### 8 Design No. (The design No. is subject to change)

## 3 4: Appendix 1

### ● JIS graphic symbols for hydraulic system

	3	4	3	4	3	4	3	4	3	4
Code	S	1	S	2	W	1	W	2	T	-
JIS graphic symbols for hydraulic system										

## 5 6 7: Appendix 2

### ● Numbers of relief valves and relief valve positions

Number of relief valves	Relief valve position		
	5	6	7
S: 1	(Right)	-	-
W: 2	(Left)	(Right)	-
T: 3	(Left)	(Center)	(Right)

Note: The table indicates the positions of built-in relief valves. See the JIS graphic symbols for hydraulic system and external dimensions for details.

## Appendix 3

### ● Combinations of pressure adjustment ranges and pressure adjusting mechanisms

Pressure adjustment range MPa {kgf/cm <sup>2</sup> }	Pressure adjusting mechanism	
	Handle adjusting type	Screw adjusting type
1.5 to 7 {15 to 70}	1	4
1.5 to 16 {15 to 160}	2	5
1.5 to 25 {15 to 250}	3	6

Note: Enter one of the numbers 1 to 6 given in the table in fields 5, 6, and 7.

## Specifications

Model code	Nominal diameter	Pressure adjustment range MPa {kgf/cm <sup>2</sup> }	Maximum flow rate L/min	Mass kg
MRV-S1 -⊗ -10	1/4	See appendix table 3.	1.5	1.5
MRV-S2 -⊗ -10				2.1
MRV-W1 -⊗⊗ -10				2.8
MRV-W2 -⊗⊗ -10				
MRV-T -⊗⊗⊗ -10				

Model code	Pressure change MPa {kgf/cm <sup>2</sup> } per handle revolution
MRV-⊗⊗-1 (4)	2.5 {25}/revolution
MRV-⊗⊗-2 (5)	4.6 {46}/revolution
MRV-⊗⊗-3 (6)	7.9 {79}/revolution

## Contact Details

Before using the product, please check the guide pages at the front of this catalog.

Internet

<https://www.daikinpmc.com/en/>

For latest information, PDF catalogs and operation manuals

## Sub-plate model code

- The sub-plate is not provided with the valve. Order it separately as required by specifying the model code given in the table below.

Model code	Nominal diameter	Connection port diameter	Mass kg
JS-01M02	1/4	Rc1/4	0.4

Refer to Page S-9 for the dimensions of the sub-plate.

## Handling

- Directly connect the tank piping of the valve to the tank without merging it with other tank piping.
- Since excessive internal volume of the pilot line piping may lead to vibration, use steel pipes with an inner diameter of 4 mm maximum and with thick walls for this piping.
- Mounting bolts are not provided with the valve. Order the following bolts separately as required.

Mounting bolt model code	Hexagon socket head cap bolt
HB101	M5 × 85 (4 pcs.)

## Example of use (with triple pressure control)

### Performance curves (viscosity: 32 mm<sup>2</sup>/s {cSt})

Flow rate - pressure characteristics

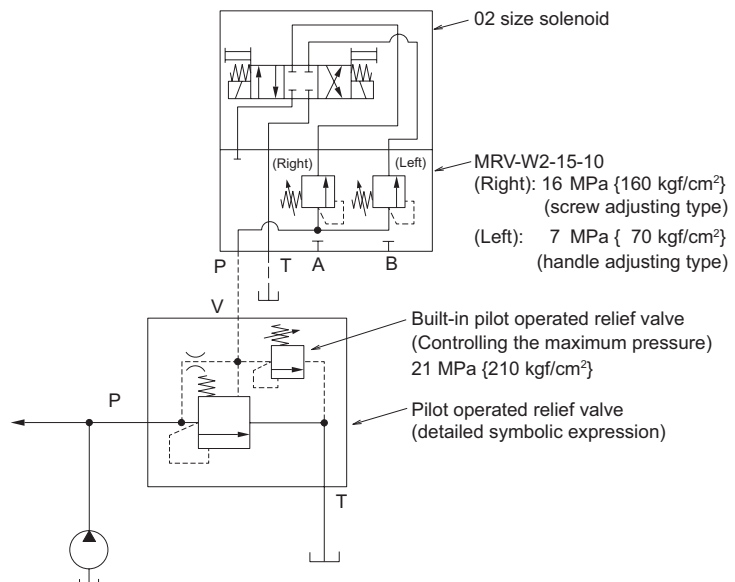
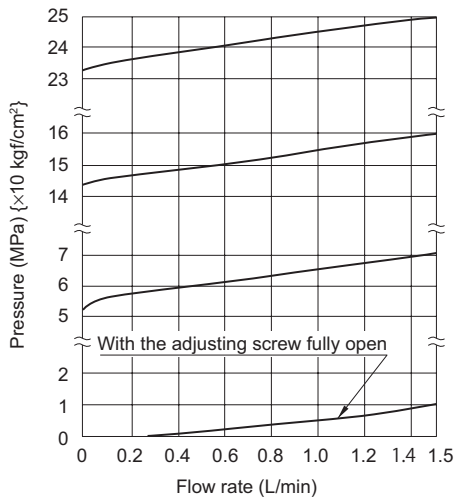

## External dimension diagram

MRV-S×-×

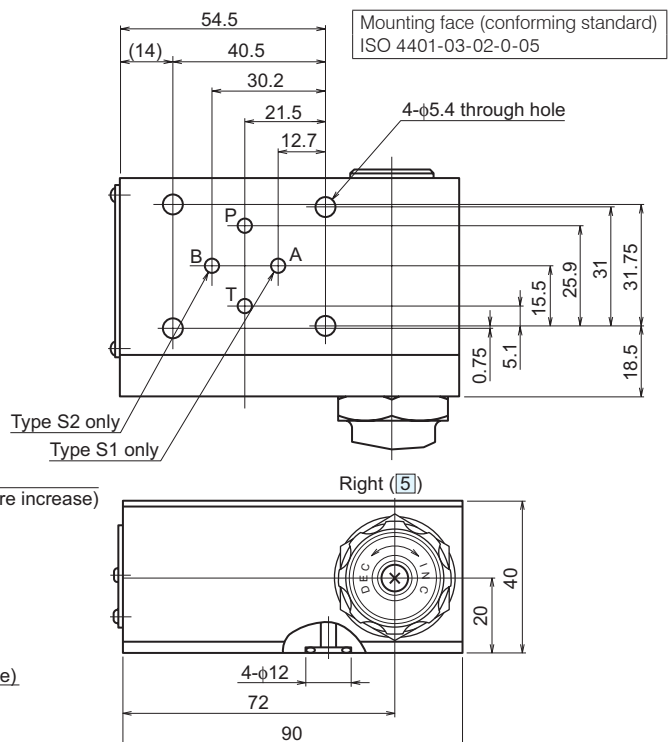
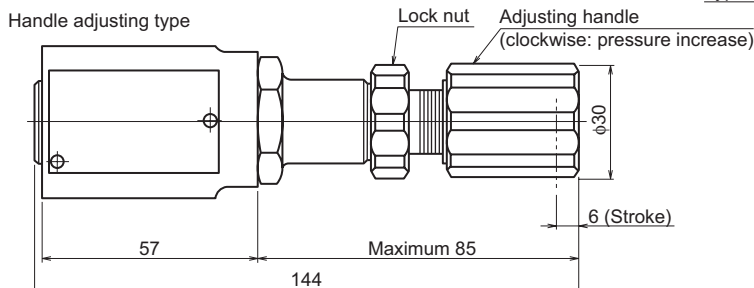
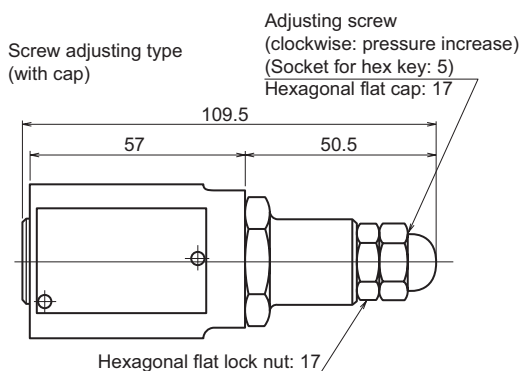

## Contact Details

Before using the product, please check the guide pages at the front of this catalog.

Internet

<https://www.daikinpmc.com/en/>

For latest information, PDF catalogs and operation manuals

## External dimension diagram

MRV-W\*-\*\*

Mounting face (conforming standard)  
ISO 4401-03-02-0-05

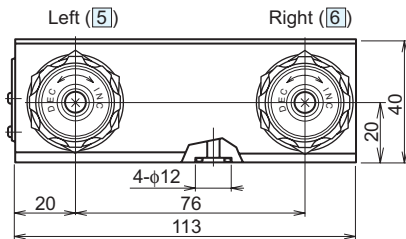
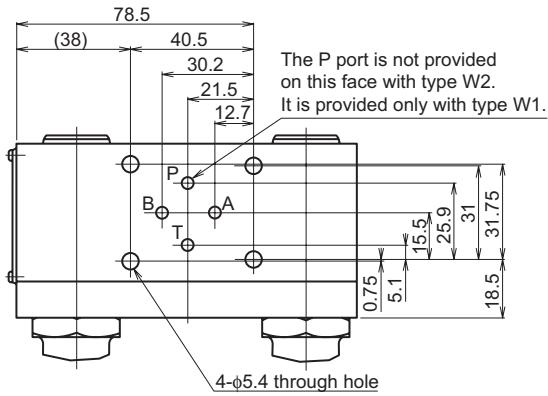

MRV-T\*-\*\*

Mounting face (conforming standard)  
ISO 4401-03-02-0-05

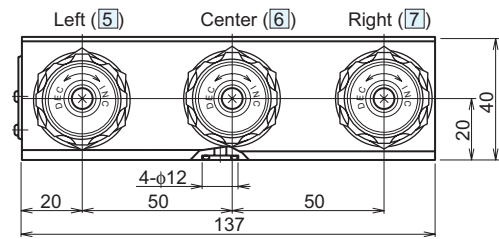
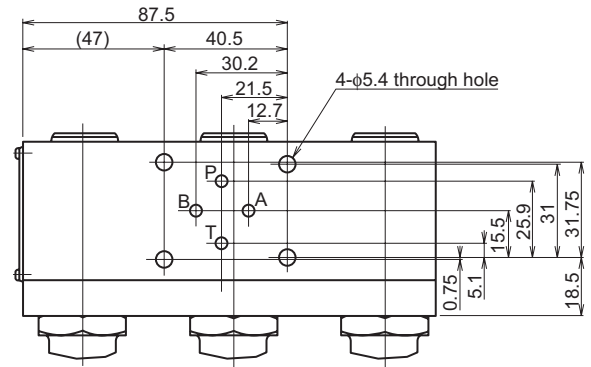

## Sectional structural diagram

MRV

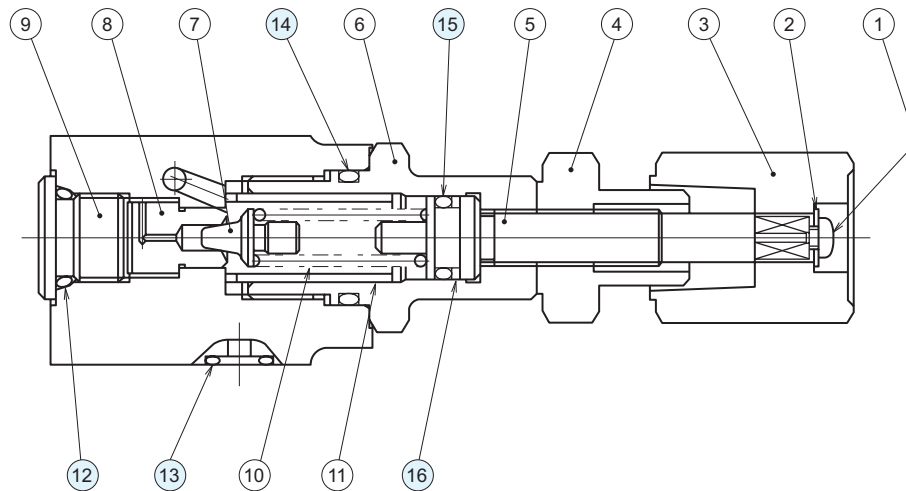

Sealing part table

Part No.	Name	Quantity	Part specifications
12	O-ring	S: 1, W: 2, T: 3	JIS B 2401 1BP14
13	O-ring	4	JIS B 2401 1BP9
14	O-ring	S: 1, W: 2, T: 3	JIS B 2401 1BP20
15	O-ring	S: 1, W: 2, T: 3	JIS B 2401 1BP11
16	Backup ring	S: 1, W: 2, T: 3	JIS B 2407 bias cut P11