

Contact Details

Before using the product, please check the guide pages at the front of this catalog.

Internet

<https://www.daikinpmc.com/en/>

For latest information, PDF catalogs and operation manuals

External dimension diagram

CR-S02

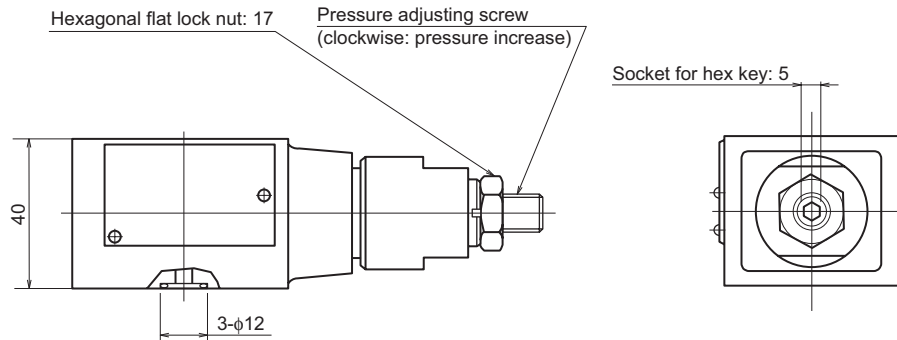
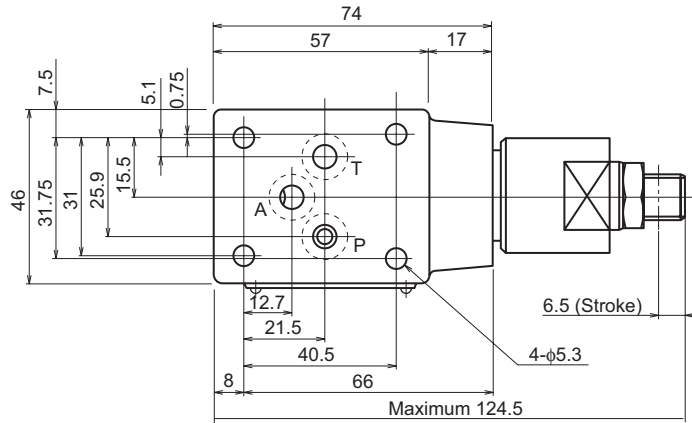

Sectional structural diagram

CR-G02P

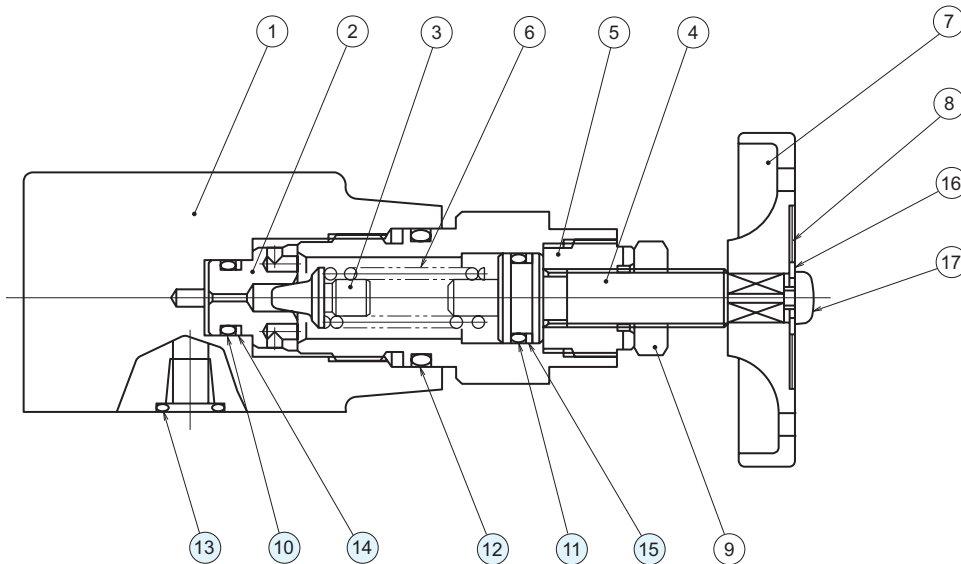

Sealing part table

Part No.	Name	Quantity		Part specifications
		CR-G02P	CR-S02※	
10	O-ring	1	1	JIS B 2401 1BP10
11	O-ring	1	1	AS568-014 (NBR, Hs90)
12	O-ring	1	1	JIS B 2401 1BP20
13	O-ring	2	3	JIS B 2401 1BP9
14	Backup ring	1	1	JIS B 2407 Bias cut P10
15	Backup ring	1	1	Bias cut AS568-014