

Solenoid Pilot Operated Directional Control Valve

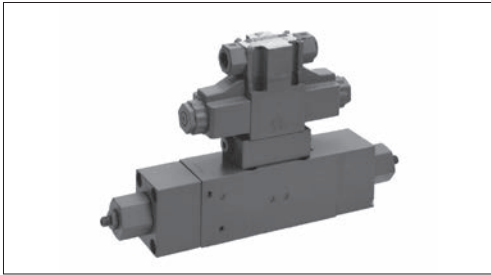

Features

- Using these valves in combination with a pressure compensation valve (MUV, MDM) achieves flow rate characteristics with pressure compensation according to the adjustment made with the flow rate adjusting screw.
- This model provide the shock reduction function of a solenoid pilot operated directional control valves by themselves.
Even greater shock reduction performance can be realized by inserting a 02 size stack valve (throttle valve or reduction valve) in the pilot line.
- It is possible to configure a multi-purpose valve block by stacking with solenoid operated proportional directional control valves (MEV).

Nomenclature

※ — **MEP** ※※ ※ ※ ※ ※ ※ ※ — **60** — ※ ※
1 2 3 4 5 6 7 8 9 10 11 12

1 Applicable fluid code

No designation: Petroleum-based hydraulic fluid
 H: Water-glycol hydraulic fluid
 F: Phosphate ester hydraulic fluid

2 Model No.

MEP: Solenoid pilot operated directional control valve

3 Nominal diameter

12: ½
 16: ¾
 20: 1
 25: 1¼
 32: 1½

4 Spool type (See the spool type table)

5 Flow type (See the specifications)

1: Q1 flow
 2: Q2 flow
 3: QMAX flow

6 Spool operating method

C: Spring center type
 B: Spring offset type (with SOL.b)
 N: No-spring type (without detent)

7 Voltage code (See the voltage code table)

8 Pilot/drain type code

X: Internal pilot, internal drain type
 Y: External pilot, external drain type
 Z: External pilot, internal drain type
 N: Internal pilot, external drain type

※ The pilot and drain type setting cannot be changed.

9 Pilot stack valve code

O: Without stack valve
 W: With MT-02W-55
 P: With MG-02P-1-55
 G: With MT-02W-55, MG-02P-1-55

10 Design No. (The design No. is subject to change)

11 Spool differential pressure code

No designation: Differential pressure of 0.6 MPa {6 kgf/cm²}
 3: Differential pressure of 0.3 MPa {3 kgf/cm²}

12 Solenoid pilot valve option code

No designation: Terminal box type
 D: No-spring type (with detent)

For options other than the ones given above, see the option code table for KSO-G02 on Page G-16

Specifications

Model No.	Nominal diameter	Port diameter	Maximum operating pressure *1 MPa {kgf/cm ² }	Maximum flow rate *2 L/min			Pilot pressure *1 MPa {kgf/cm ² }	Permissible back pressure MPa {kgf/cm ² }	Fluid drainage volume at spool switching cm ³
				Q1	Q2	QMAX			
MEP12	12	½	21 {210}	25	50	75	0.8 to 14 {8 to 140}	10 {100}	1.4
MEP16	16	¾		50	100	130			3.1
MEP20	20	1		80	160	200			5.9
MEP25	25	1¼		125	250	300			9.9
MEP32	32	1½		200	400	500			15.4

Note: *1 When the maximum operating pressure exceeds 14 MPa {140 kgf/cm²}, select the external pilot type with a pilot pressure of 14 MPa {140 kgf/cm²} maximum. When a pilot pressure beyond 14 MPa {140 kgf/cm²} is required with the internal pilot type, select the specifications with MG-02P-1-55 (option code: P).

*2 The maximum flow rates Q1 and Q2 show the values when equipped with an inlet valve block with a spring for a differential pressure of 0.6 MPa {6 kgf/cm²} or 0.3 MPa {3 kgf/cm²}, and QMAX shows the values when equipped with an inlet valve block with a spring for a differential pressure of 0.6 MPa {6 kgf/cm²}. When multiple series of valves with a pressure compensation valve are configured, the maximum flow rate may not be reached at the second or later series of valves. Take 80% of the maximum flow rate as the guide at the third series.

Refer to KSO-G02 on Page G-16 for the solenoid specifications.

Contact Details







Before using the product, please check the guide pages at the front of this catalog.

Internet

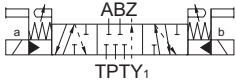
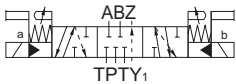
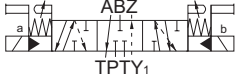
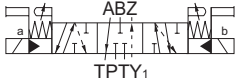
<https://www.daikinpmc.com/en/>

For latest information, PDF catalogs and operation manuals

4 Spool type table

Spool type Meter-in spool *3	JIS graphic symbols for hydraulic system	Spool type Meter-out spool *4	JIS graphic symbols for hydraulic system
A		P	
B		Q	
C		R	
D		S	
F			

Note: *3 Although the maximum opening levels from P to A and from P to B vary depending on Q1, Q2 and QMAX, the opening levels from A to T and from B to T are always equivalent to QMAX.

*4 Although the maximum opening levels from A to T and from B to T vary depending on Q1, Q2 and QMAX, the opening levels from P to A and from P to B are always equivalent to three times QMAX.

○ The spool is the same as that of solenoid operated proportional directional control valves (MEV).

7 Voltage code table

Voltage code	Power supply voltage	Voltage code	Power supply voltage
A	AC 100 V (50/60 Hz), AC 110 V (60 Hz)	N	DC 12 V
B	AC 200 V (50/60 Hz), AC 220 V (60 Hz)	P	DC 24 V
C	AC 110 V (50 Hz)	Q	DC 48 V
D	AC 220 V (50 Hz)	R	DC 100 V
J	AC 240 V (50/60 Hz)	S	DC 110 V
K	AC 120 V (50/60 Hz)	T	DC 200 V
L	AC 115 V (50/60 Hz)	U	DC 220 V
M	AC 230 V (50/60 Hz)	E	AC 100 V (50/60 Hz) with rectifier
		F	AC 110 V (50/60 Hz) with rectifier
		G	AC 200 V (50/60 Hz) with rectifier
		H	AC 220 V (50/60 Hz) with rectifier

See the solenoid specification table for KSO-G02 on Page G-16 for solenoid specifications.

Mass (kg)

Model No.	(1)	(2)	(3)	(4)
MEP12	6.5	7.9	7.8	9.2
MEP16	9	10.4	10.3	11.7
MEP20	14.4	15.8	15.7	17.1
MEP25	19.1	20.5	20.4	21.8
MEP32	27.9	29.3	29.2	30.6

Solenoid pilot valve model code

Model code	Applicable solenoid valve model code (※: Voltage code)
MEP****C**-60-**	KSO-G02-4C*-30
MEP****B**-60-**	KSO-G02-8B*-30-4T
MEP****N**-60-**	KSO-G02-2N*-30
MEP****N**-60-**D	KSO-G02-2D*-30

Note: Mass (1) Pilot stack valve code: O (without stack valve)

(2) Pilot stack valve code: W (with MT-02W-55)

(3) Pilot stack valve code: P (with MG-02P-1-55)

(4) Pilot stack valve code: G (with MT-02W-55, MG-02P-1-55)

Contact Details

Before using the product, please check the guide pages at the front of this catalog.

Internet

<https://www.daikinpmc.com/en/>

For latest information, PDF catalogs and operation manuals

Accessories

Model No.	Hexagon socket head cap bolt	Quantity	Tightening torque N·m {kgf·cm}
MEP12	M6 × 25	4	12 to 15 {120 to 150}
MEP16	M8 × 35	4	25 to 30 {250 to 300}
MEP20	M10 × 50	4	48 to 63 {480 to 630}
MEP25	M8 × 50	8	25 to 30 {250 to 300}
MEP32	M10 × 45	8	48 to 63 {480 to 630}

Handling

- Maintain the pressure difference between the pilot pressure and drain pressure no lower than 0.8 MPa {8 kgf/cm²}. The spool starts moving at a differential pressure of 0.6 MPa {6 kgf/cm²}.

JIS graphic symbols for hydraulic system (detail)

● MEP*****O

(Symbol for pilot stack valve: O)

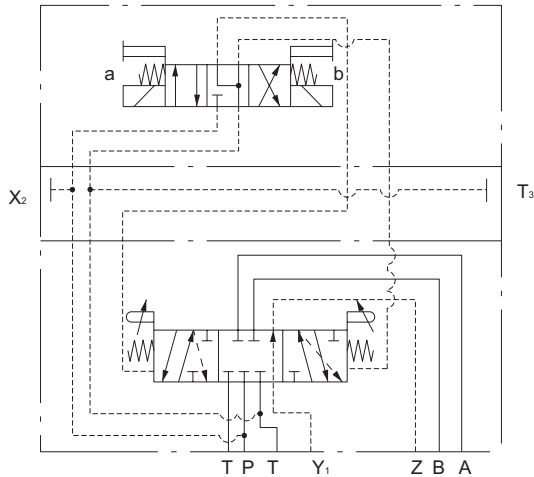

● MEP*****W

(Pilot stack valve code: W)

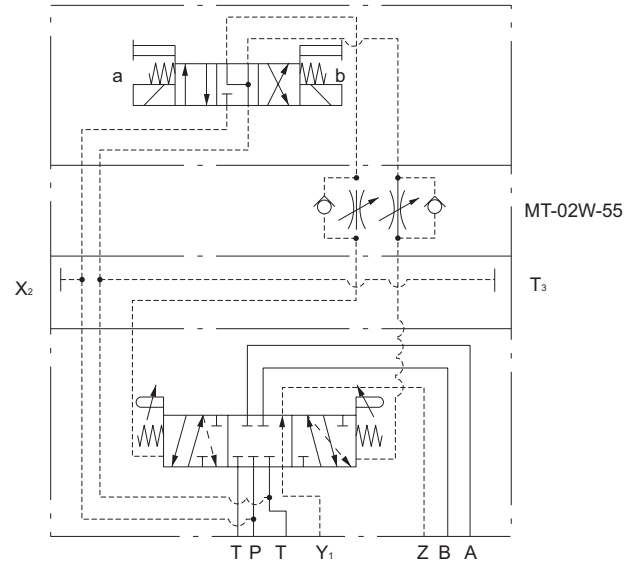

● MEP*****P

(Pilot stack valve code: P)

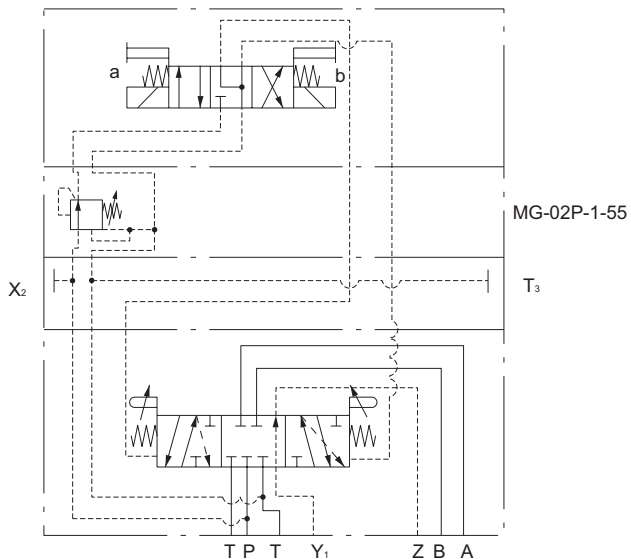

● MEP*****G

(Pilot stack valve code: G)

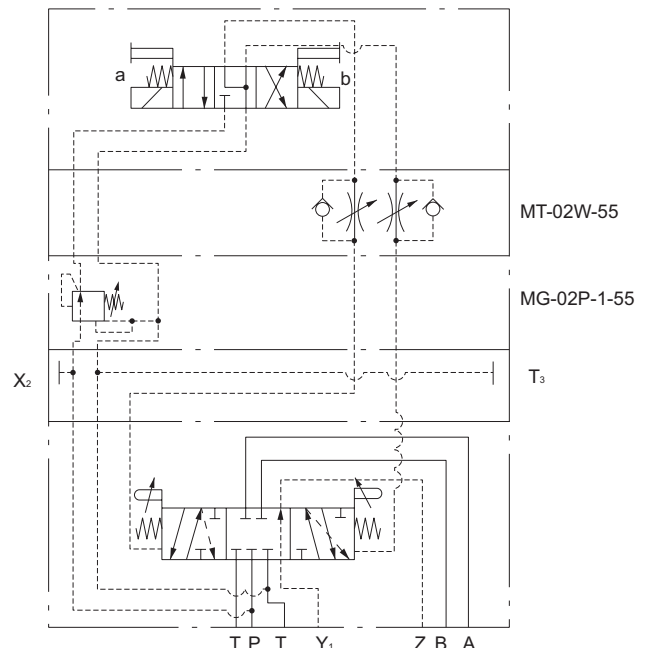

External dimension diagram

- MEP12, 16, 20
- Pilot valve stack type: Type W

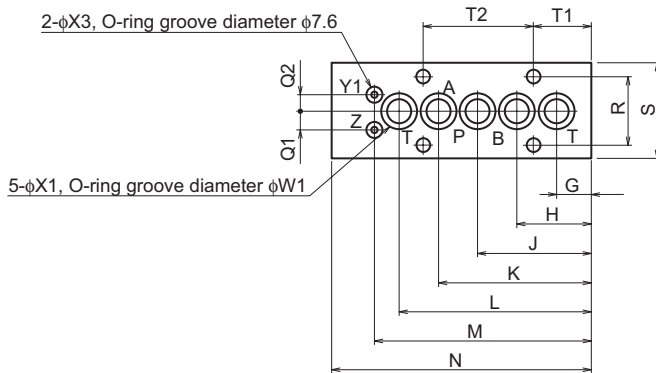
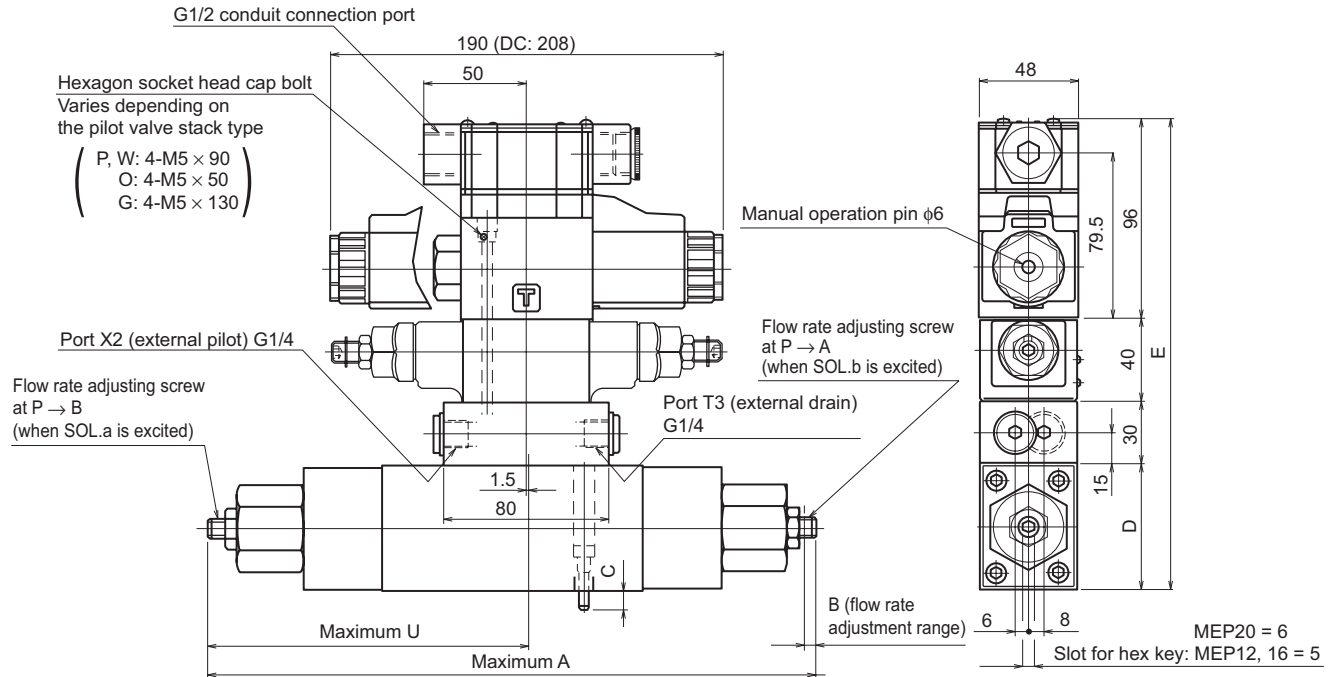

- Pilot valve stack type: Type P

- Pilot valve stack type: Type O

- Pilot valve stack type: Type G

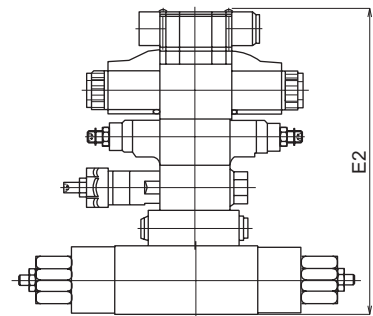
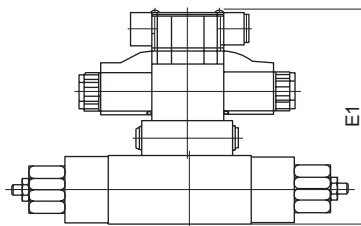
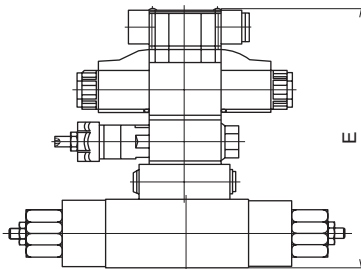

Nominal diameter	Dimensions																							
	A	B	C	D	E	E1	E2	G	H	J	K	L	M	N	Q1	Q2	R	S	T1	T2	W1	X1	X3	U
12	294.6	6	9	60	226	186	239	17	36	55	74	93	105	126	9	8	33	46	28.3	53.2	17.2	12	3	155.5
16	347	7.5	10	70	236	196	276	22	46	70	94	118	134	158	10	10	40	55	40	60	22	16	4	182.5
20	423	9	11	86	252	212	292	25	55	85	115	145	162	190	15	14.5	50	68	42	86	26.9	20	4	221.5

External dimension diagram

● MEP25, 32

Pilot valve stack type: Type W

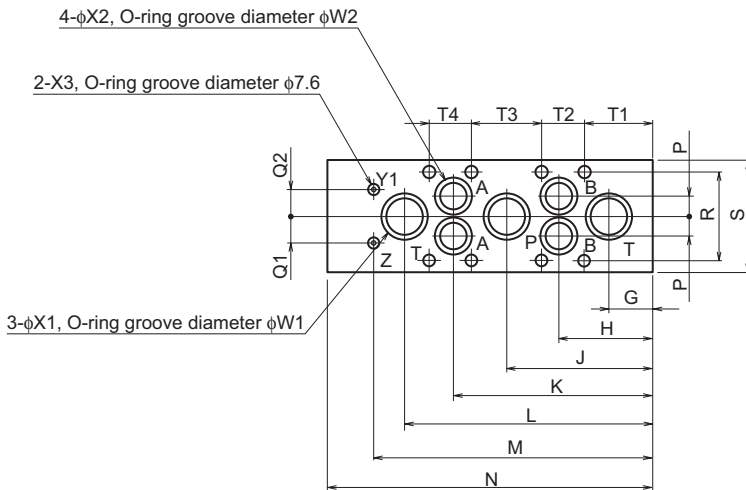
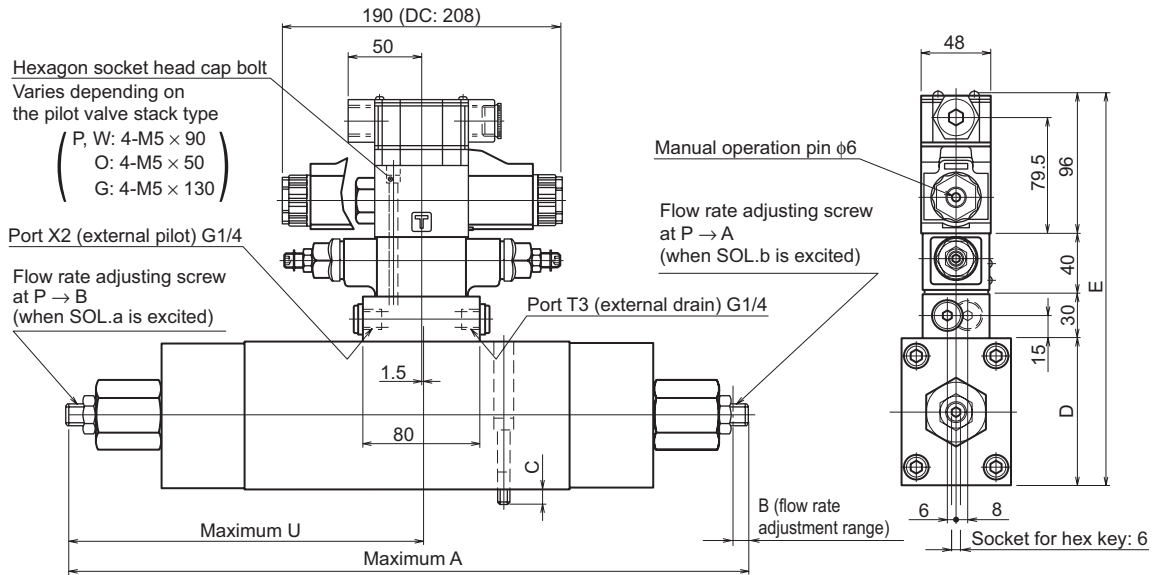

Nominal diameter	Dimensions													
	A	B	C	D	E	E1	E2	G	H	J	K	L	M	N
25	463.6	10.5	10	100	266	226	306	30	64	100	136	170	191	223
32	516	12	10	120	286	246	326	33.5	74.5	117.5	160.5	201.5	226	263

Nominal diameter	Dimensions														
	P	Q1	Q2	R	S	T1	T2	T3	T4	W1	W2	X1	X2	X3	U
25	13.5	18.5	18	60	76	47	29	48	29	31.6	25.3	25	18	4	243.5
32	16	21.5	21	70	90	54.5	34.5	57	34.5	38	30	32	23	4	272

Contact Details

Before using the product, please check the guide pages at the front of this catalog.

Internet

<https://www.daikinpmc.com/en/>

For latest information, PDF catalogs and operation manuals

Sectional structural diagram

● MEP12, 16, 20

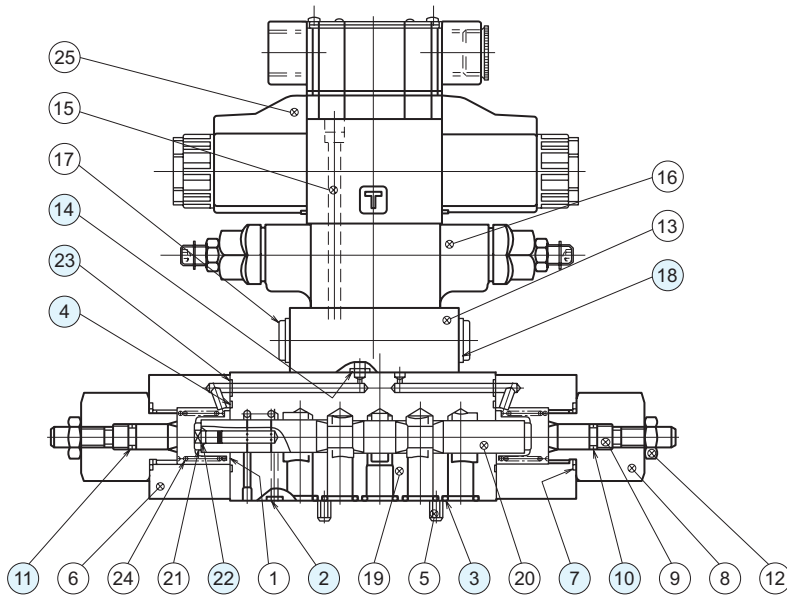

Part No.	Name	Quantity	Part specifications			Part specifications
			MEP-12	MEP-16	MEP-20	
2	O-ring	2	AS568-008	AS568-008	AS568-008	NBR, Hs90
3	O-ring	5	AS568-112	AS568-115	AS568-118	NBR, Hs90
4	O-ring	2	AS568-025	AS568-128	AS568-136	NBR, Hs90
7	O-ring	2	AS568-024	AS568-024	AS568-026	NBR, Hs90
10	O-ring	2	1B P9	1B P9	1B P12	JIS B 2401
11	Backup ring	2	P9	P9	P12	JIS B 2407 bias cut
14	O-ring	4	AS568-010	AS568-010	AS568-010	NBR, Hs90
18	Sealing washer	2	KP-C-02	KP-C-02	KP-C-02	
22	O-ring	1	1B P5	1B P5	1B P10A	JIS B 2401
23	O-ring	2	AS568-008	AS568-008	AS568-009	NBR, Hs90

● MEP25, 32

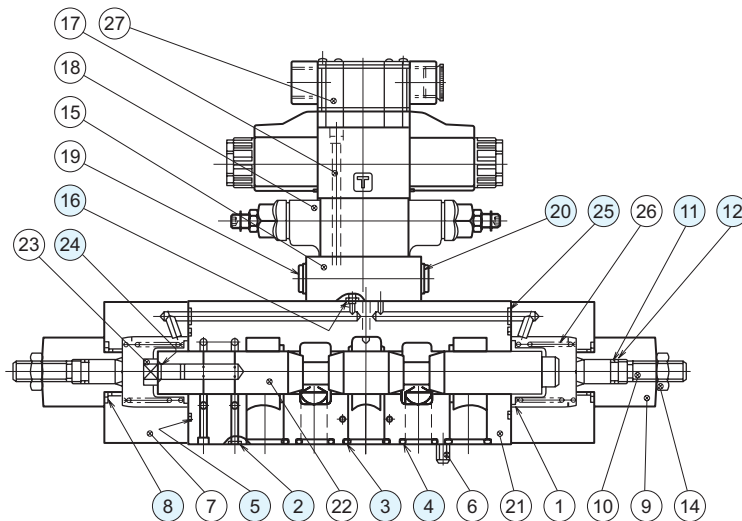

Part No.	Name	Quantity	Part specifications		Part specifications
			MEP-25	MEP-32	
2	O-ring	2	AS568-008	AS568-008	NBR, Hs90
3	O-ring	3	AS568-121	AS568-125	NBR, Hs90
4	O-ring	4	AS568-117	AS568-120	NBR, Hs90
5	O-ring	2	AS568-228	AS568-231	NBR, Hs90
8	O-ring	2	AS568-026	AS568-026	NBR, Hs90
11	O-ring	2	1B P12	1B P12	JIS B 2401
12	Backup ring	2	P12	P12	JIS B 2407 bias cut
16	O-ring	4	AS568-010	AS568-010	NBR, Hs90
20	Sealing washer	2	KP-C-02	KP-C-02	
24	O-ring	1	1B P10A	1B P12	JIS B 2401
25	O-ring	2	AS568-009	AS568-009	NBR, Hs90