

## Contact Details

Before using the product, please check the guide pages at the front of this catalog.

Internet

<https://www.daikinpmc.com/en/>

For latest information, PDF catalogs and operation manuals

# 02 Series Stacking Type Relief Valves

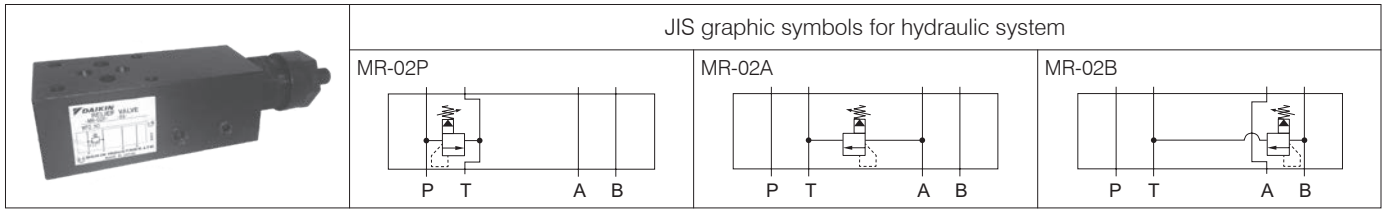

## Nomenclature

※ - MR - 02 ※ - ※ - ※※ - ※ ※  
 1 2 3 4 5 6 7 8

### 1 Applicable fluid code

No designation: Petroleum-based hydraulic fluid,  
 water-glycol hydraulic fluid  
 F: Phosphate ester hydraulic fluid

### 2 Model No.

MR: Modular stacking type relief valve

### 3 Nominal diameter

02: 1/4

### 4 Control port

P: Port P  
 A: Port A  
 B: Port B

### 5 Pressure adjustment range

1: Up to 7 MPa {Up to 70 kgf/cm<sup>2</sup>}  
 2: 3.5 to 16 MPa {35 to 160 kgf/cm<sup>2</sup>}  
 3: 3.5 to 25 MPa {35 to 250 kgf/cm<sup>2</sup>}  
 4: 7.0 to 35 MPa {70 to 350 kgf/cm<sup>2</sup>} (applicable only to design No. 60)

### 6 Design No. (The design No. is subject to change)

55: 25 MPa {250 kgf/cm<sup>2</sup>} series  
 60: 35 MPa {350 kgf/cm<sup>2</sup>} series

### 7 Pressure adjusting screw position

No designation: Adjusted at port B side  
 G: Adjusted at port A side (applicable only to design No. 55)

### 8 Option code

No designation: Pressure adjusting screw type  
 T: Pressure adjusting handle type

## Specifications

Model code	Maximum operating pressure MPa {kgf/cm <sup>2</sup> }	Maximum flow rate L/min	Pressure adjustment range *1 MPa {kgf/cm <sup>2</sup> }	Mass kg	Pressure change MPa {kgf/cm <sup>2</sup> } per screw revolution
MR-02※-1-55	25 {250}	40	Up to 7 {Up to 70}	1.4	2.5 {25}/revolution
MR-02※-2-55			3.5 to 16 {35 to 160}		4.6 {46}/revolution
MR-02※-3-55			3.5 to 25 {35 to 250}		7.9 {79}/revolution
MR-02※-1-60	35 {350}		Up to 7 {Up to 70}	1.5	2.5 {25}/revolution
MR-02※-2-60			3.5 to 16 {35 to 160}		4.6 {46}/revolution
MR-02※-3-60			3.5 to 25 {35 to 250}		7.9 {79}/revolution
MR-02※-4-60			7.0 to 35 {70 to 350}		9 {90}/revolution

Note: \*1 The minimum adjustment pressure varies depending on the flow rate. See the minimum adjustment pressure characteristics for details.

## Handling

- Maintain the back pressure of the tank port at no greater than 0.5 MPa {5 kgf/cm<sup>2</sup>}.
- When using the valve as a safety valve, set the pressure 1 to 1.5 MPa {10 to 15 kgf/cm<sup>2</sup>} higher than the pressure set for the hydraulic circuit.

## Performance curves (viscosity: 32 mm<sup>2</sup>/s {cSt})

### Pressure drop characteristics

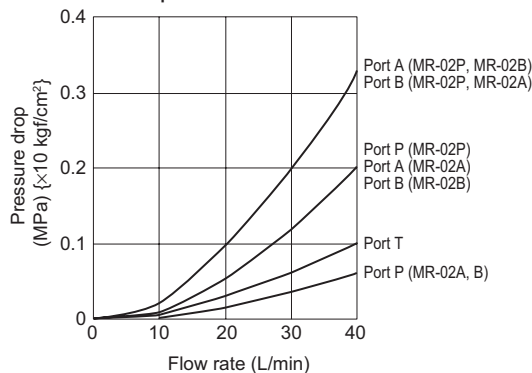

### Pressure - Flow rate characteristics

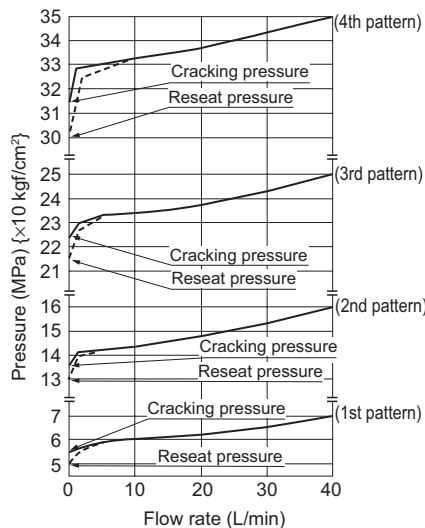

### Minimum adjustment pressure characteristics

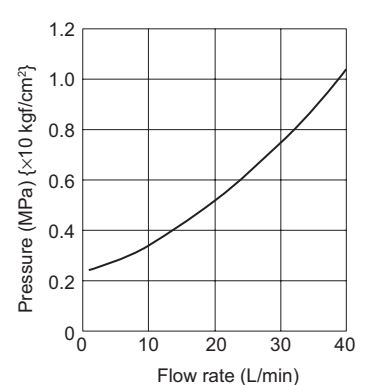

## Contact Details

Before using the product, please check the guide pages at the front of this catalog.

Internet

<https://www.daikinpmc.com/en/>

For latest information, PDF catalogs and operation manuals

## External dimension diagram

MR-02※-※-55

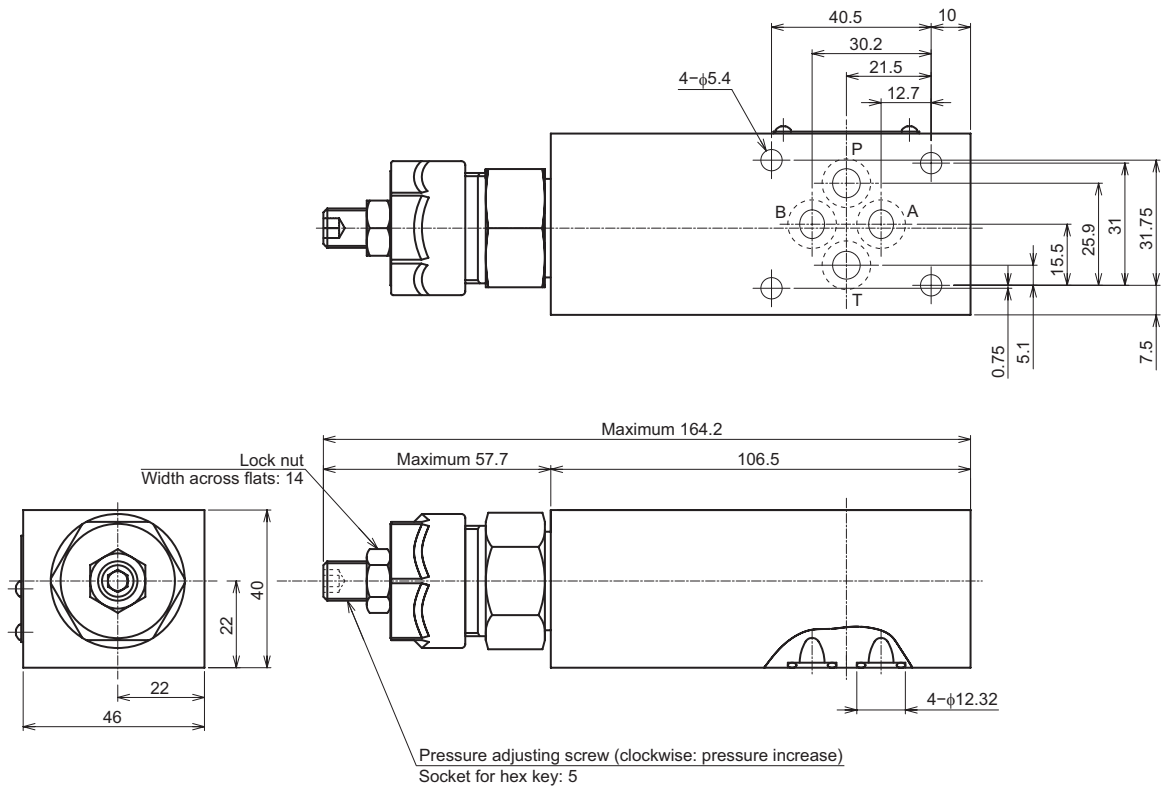

For products with option code G, the pressure adjusting screw is located at the port A side.

## Sectional structural diagram

MR-02※-※-55

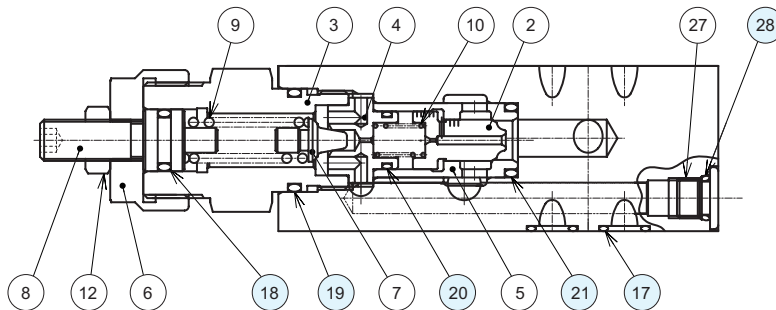

Sealing part table

Part No.	Name	Quantity	Part specifications
17	O-ring	4	AS568-012 (NBR, Hs90)
18	O-ring	1	JIS B2401 1B P11
19	O-ring	1	JIS B2401 1A P21
21	O-ring	1	JIS B2401 1B P14
20	O-ring	1	AS568-013 (NBR, Hs90)
28	O-ring	1	JIS B2401 1B P8

## Contact Details

Before using the product, please check the guide pages at the front of this catalog.

Internet

<https://www.daikinpmc.com/en/>

For latest information, PDF catalogs and operation manuals

## External dimension diagram

MR-02\*-\*-60

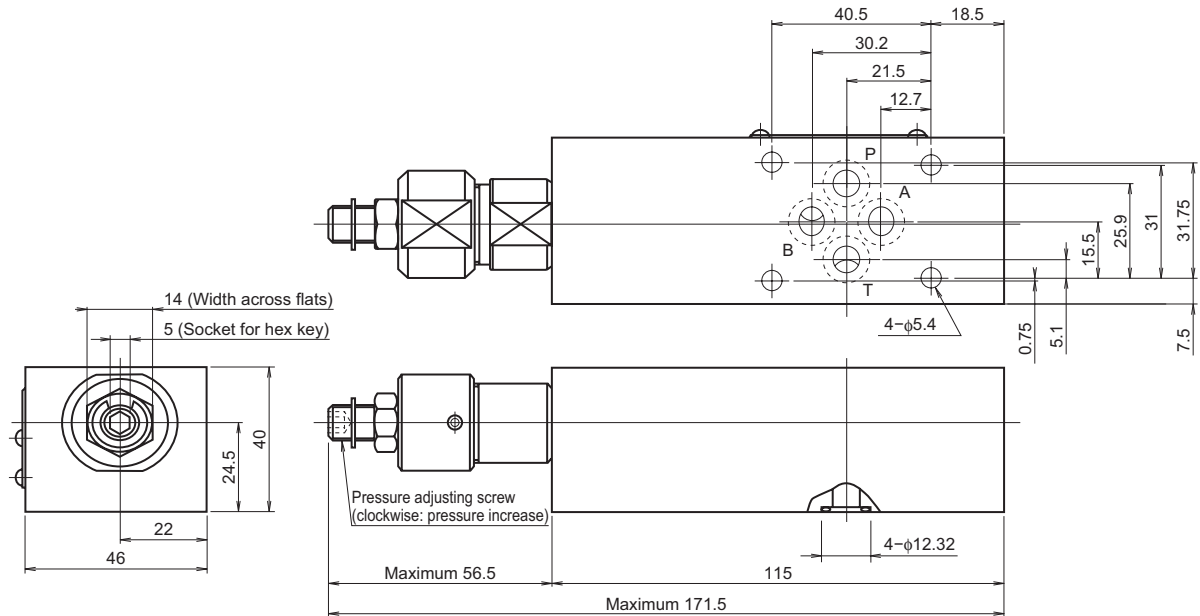

MR-02\*-\*-60-T

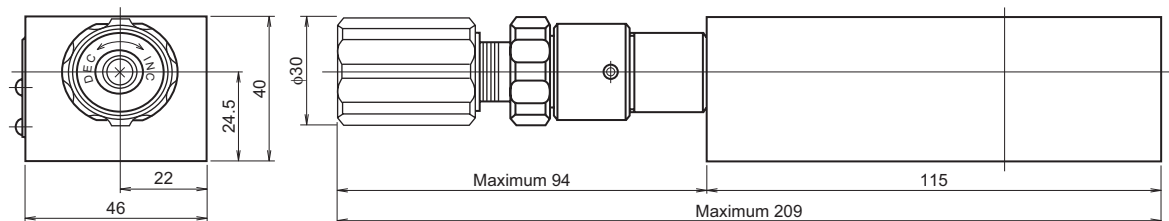

## Sectional structural diagram

MR-02\*-\*-60

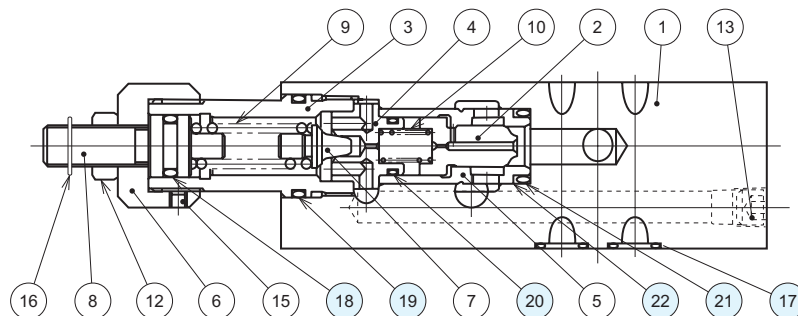

Sealing part table

Part No.	Name	Quantity	Part specifications
17	O-ring	4	AS568-012 (NBR, Hs90)
18	O-ring	1	JIS B 2401 1A P11
19	O-ring	1	JIS B 2401 1A P21
20	O-ring	1	AS568-013 (NBR, Hs90)
21	O-ring	1	JIS B 2401 1B P14
22	Backup ring	1	JIS B 2407 Bias cut P14