

Contact Details

Before using the product, please check the guide pages at the front of this catalog.

Internet

<https://www.daikinpmc.com/en/>

For latest information, PDF catalogs and operation manuals

03 Series Stacking Type Port A/B Relief Valves

JIS graphic symbols for hydraulic system

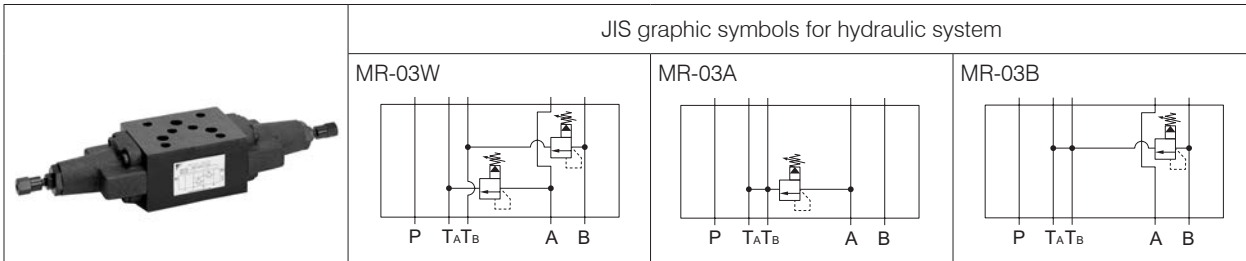

Nomenclature

※ - **MR** - **03** ※ - ※ - **45**
1 2 3 4 5 6

1 Applicable fluid code

No designation: Petroleum-based hydraulic fluid,
water-glycol hydraulic fluid
F: Phosphate ester hydraulic fluid

2 Model No.

MR: Modular stacking type relief valve

3 Nominal diameter

03: $\frac{3}{8}$

4 Control port

W: Port A/B
A: Port A
B: Port B

5 Pressure adjustment range

1: 0.8 to 7 MPa { 8 to 70 kgf/cm² }
3: 3.5 to 25 MPa { 35 to 250 kgf/cm² }

6 Design No.

(The design No. is subject to change)

Specifications

Model code	Maximum operating pressure MPa {kgf/cm ² }	Maximum flow rate L/min	Pressure adjustment range *1 MPa {kgf/cm ² }	Mass kg
MR-03W-1-45	25 {250}	80	Up to 7 {Up to 70}	3.9
MR-03W-3-45			3.5 to 25 {35 to 250}	
MR-03A-1-45			Up to 7 {Up to 70}	3.1
MR-03A-3-45			3.5 to 25 {35 to 250}	
MR-03B-1-45			Up to 7 {Up to 70}	
MR-03B-3-45			3.5 to 25 {35 to 250}	

Note: *1 The minimum adjustment pressure varies depending on the flow rate. See the minimum adjustment pressure characteristics for details.

Handling

- Maintain the back pressure of the tank port at no greater than 0.2 MPa {2 kgf/cm²}.
- When using the valve as a safety valve, set the pressure 1 to 1.5 MPa {10 to 15 kgf/cm²} higher than the pressure set for the hydraulic circuit.
- Use the valve with a flow rate of 8 L/min minimum since the pressure setting may be unstable if the flow rate is too low.

Performance curves (viscosity: 32 mm²/s {cSt})

Pressure - Flow rate characteristics

MR-03※-1-45

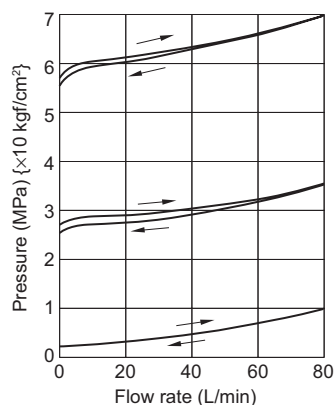

MR-03※-3-45

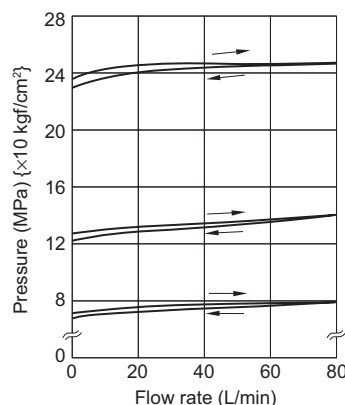

Minimum adjustment pressure characteristics

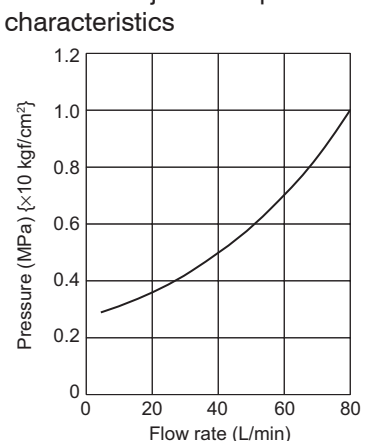

Contact Details

Before using the product, please check the guide pages at the front of this catalog.

Internet

<https://www.daikinpmc.com/en/>

For latest information, PDF catalogs and operation manuals

External dimension diagram

MR-03W

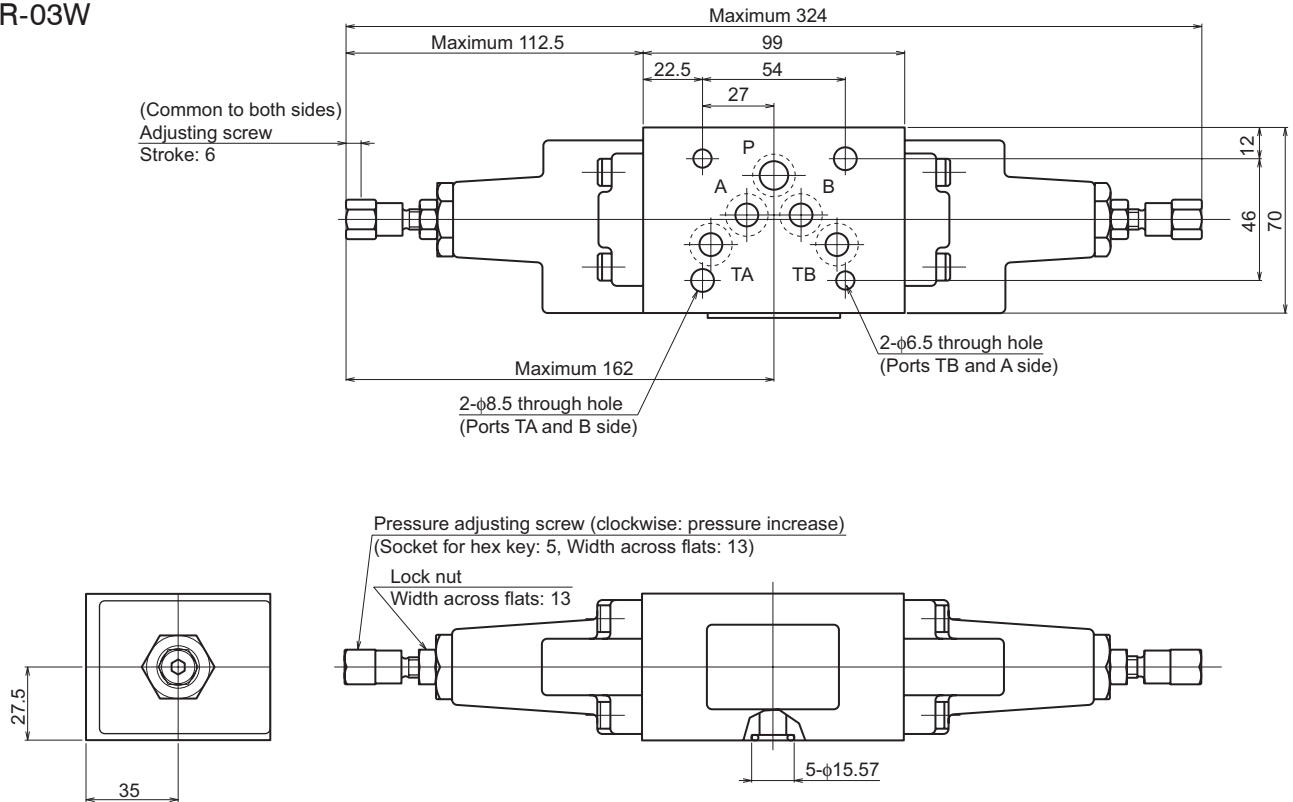

MR-03A

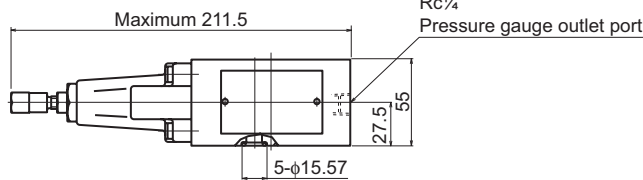

MR-03B

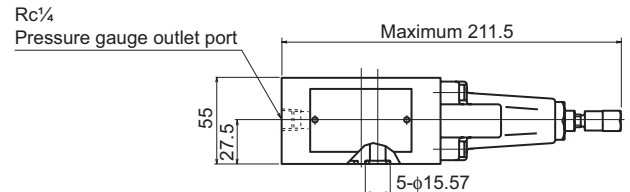

Sectional structural diagram

MR-03W

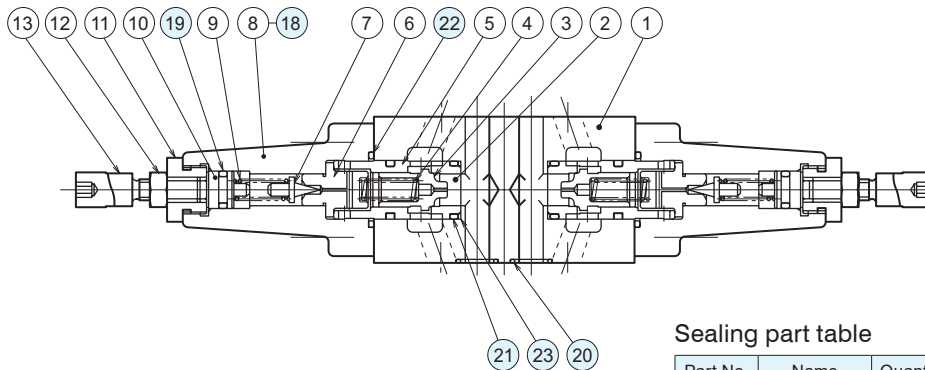

Sealing part table

Part No.	Name	Quantity	Part specifications
18	O-ring	2	JIS B 2401 1B P7
19	O-ring	2	JIS B 2401 1A P10A
20	O-ring	5	AS568-014 (NBR, Hs90)
21	O-ring	2	JIS B 2401 1B P18
22	O-ring	2	AS568-119 (NBR, Hs90)
23	Backup ring	2	JIS B 2407 Bias cut P18