

Contact Details

Before using the product, please check the guide pages at the front of this catalog.

Internet

<https://www.daikinpmc.com/en/>

For latest information, PDF catalogs and operation manuals

Solenoid Pilot Operated Proportional Relief Valve

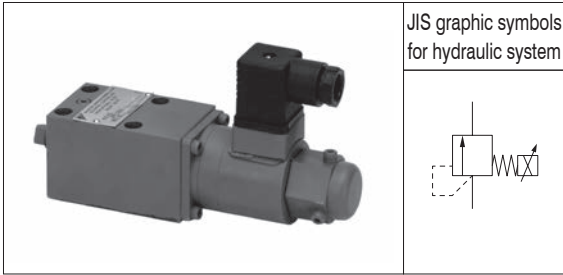

Features

- These valves are used for remotely controlling relief valves and reducing valves as the pilot operated pressure control valve or for variable displacement piston pumps as the pilot valve.

Nomenclature

※ - **JRP** - **G 02** - ※ ※ - ※ - **30** - ※ ※ ※

1 2 3 4 5 6 7 8 9 10

1 Applicable fluid code

No designation: Petroleum-based hydraulic fluid,
water-glycol hydraulic fluid
F: Phosphate ester hydraulic fluid

2 Model No.

JRP: J series solenoid pilot operated proportional relief valve

3 Connections

G: Gasket mount type

4 Nominal diameter

02: ¼

5 Pressure adjustment range

03: Up to 3.5 MPa {Up to 35 kgf/cm²}
1: Up to 7 MPa {Up to 70 kgf/cm²}
2: Up to 16 MPa {Up to 160 kgf/cm²}
3: Up to 25 MPa {Up to 250 kgf/cm²}

6 Structure code

N: Direct operated type
S: Spring balance type

7 Design No. (The design No. is subject to change)

8 Drainage code

No designation: Internal drain type
E: External drain type

9 Option code

No designation: DIN connector mounting position: Top
L: DIN connector mounting position, left side
R: DIN connector mounting position, right side

10 Solenoid codes

No designation: DC 24 V solenoid
N: DC 12 V solenoid

10: Solenoid code and applicable driver model code

Solenoid codes	Solenoid	Rated current (20°C) mA	Coil resistance (20°C) Ω	Applicable driver	
				Model code	Power supply voltage
No designation	DC 24 V solenoid	850	26	KC-6-10	AC 100, 200, 220 V (Common for 50 and 60 Hz)
N	DC 12 V solenoid	1700	6.5	ZH-6-10	DC 24 V

Specifications

Model code	Nominal diameter	Pressure adjustment range *1 MPa {kgf/cm ² }	Maximum flow rate L/min	Hysteresis	Repeatability	Mass kg
JRP-G02-03-※-30	¼	Up to 3.5 {Up to 35}	1	No greater than 3% of the maximum adjusting pressure	No greater than 1% of the maximum adjusting pressure	1.8
JRP-G02-1 -※-30		Up to 7 {Up to 70}				
JRP-G02-2 -※-30		Up to 16 {Up to 160}				
JRP-G02-3 -※-30		Up to 25 {Up to 250}				

Note: *1 The minimum adjustment pressure varies depending on the flow rate. See the minimum adjustment pressure characteristics for details.

○ When used as the pilot valve for a main valve, the minimum adjusting pressure varies depending on the main valve.

Contact Details

Before using the product, please check the guide pages at the front of this catalog.

Internet

<https://www.daikinpmc.com/en/>

For latest information, PDF catalogs and operation manuals

Sub-plate model code

- The sub-plate is not provided with the valve. Order it separately as required by specifying the model code given in the table below.

Model code	Nominal diameter	Connection port diameter	Mass kg
JS-01M02	1/4	Rc1/4	0.64

Refer to Page S-9 for the dimensions of the sub-plate.

Accessories

Hexagon socket head cap bolt	Quantity	Tightening torque N·m {kgf·cm}
M5 × 45	4	6 to 8 {60 to 80}

Handling

- Directly connect the tank piping of the valve to the tank without merging it with other tank piping.
- Since excessive internal volume of the pilot piping may lead to vibration, use steel pipes with an inner diameter of 4 mm maximum and with thick walls for this piping.
- To achieve stable pressure control, completely remove air by loosening the air bleeding screw and fill the inside of the valve with fluid.
- The minimum pressure adjusting screw (manual adjusting screw) is factory adjusted before shipment but it can be used to adjust the pressure when electric current cannot be applied to the solenoid during initial adjustment or due to electrical failure. Before adjusting the pressure with the pressure adjusting screw, check and note the initial position of the screw. The pressure is increased by turning the screw clockwise. After recovering the normal operation status, return the screw to the initial position and tighten the lock nut.
- N type (direct operated type) models have a structure where the poppet is directly operated with the proportional solenoid and this enables reduction of surge pressure in pressure control with the pressure compensator, especially when installed in a variable displacement piston pump.
S type (spring balance type) models have a structure where the poppet is operated by the proportional solenoid via a spring and this makes it possible to prevent resonance with the pulsation of the pump, resulting in improved linearity.
- Do not excite the valve continuously for 30 minutes or longer at a constant current.

Performance curves (viscosity: 32 mm²/s {cSt})

Input current -
Pressure characteristics
JRP-G02-×-N

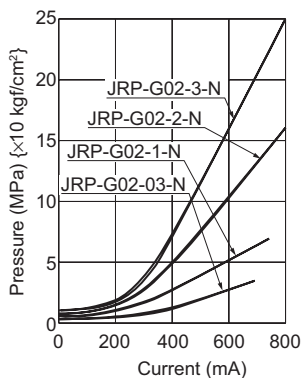

JRP-G02-×-S

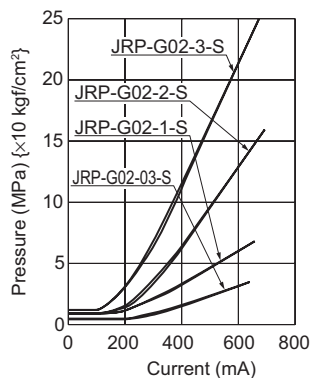

Minimum adjustment
pressure characteristics
JRP-G02-×-N

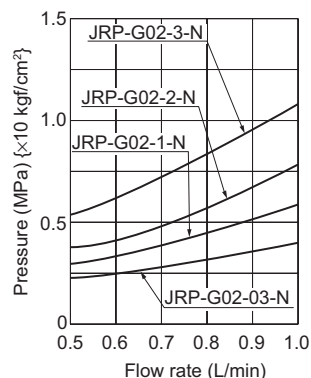

JRP-G02-×-S

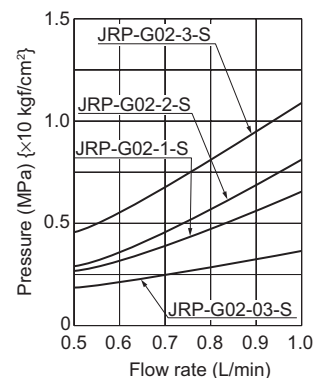

Frequency response characteristics

JRP-G02-2-×-30

Driver: KC-6-10 Pressure fluctuation: 10 ± 2 MPa

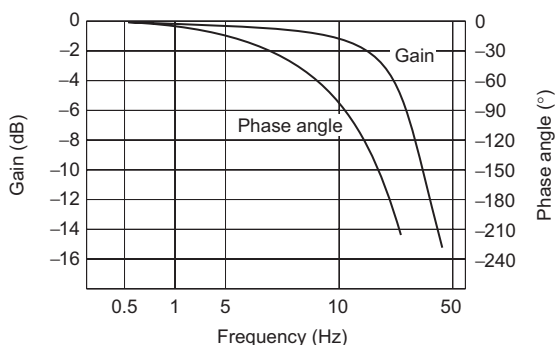

Contact Details

Before using the product, please check the guide pages at the front of this catalog.

Internet

<https://www.daikinpmc.com/en/>

For latest information, PDF catalogs and operation manuals

External dimension diagram

JRP-G02

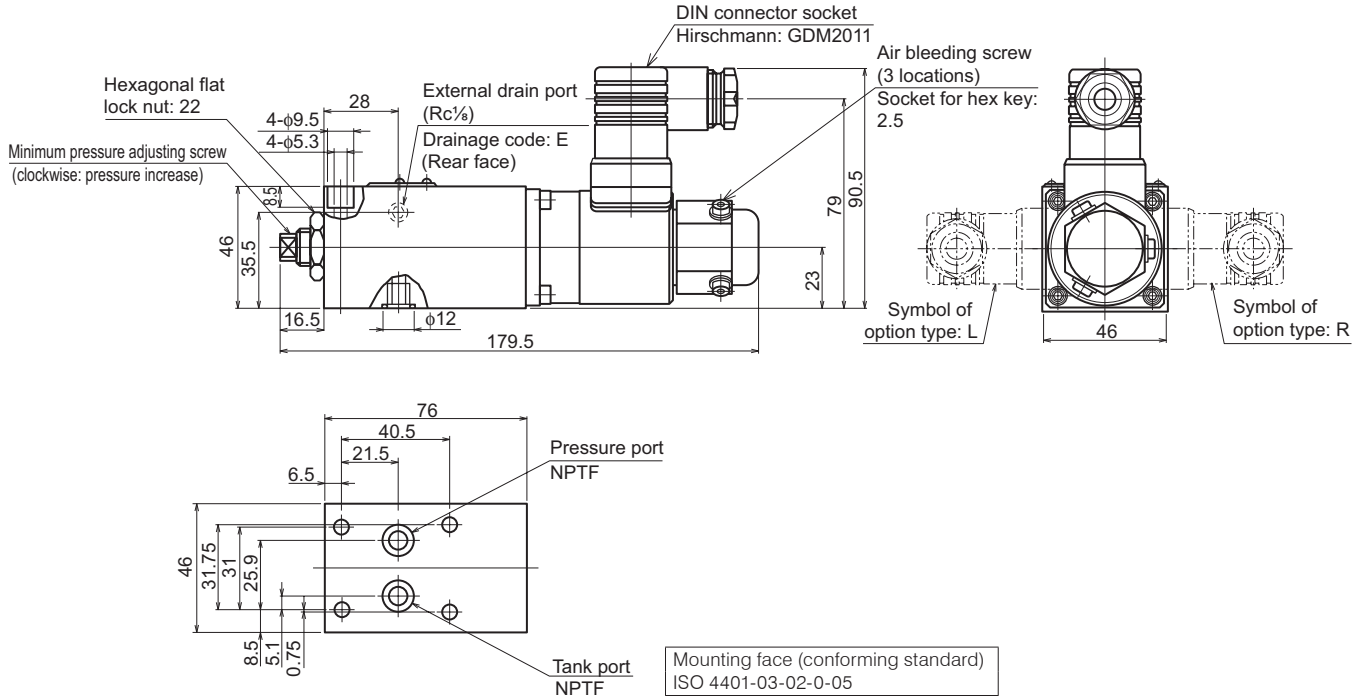

Sectional structural diagram

JRP-G02-※※-N

JRP-G02-※※-S

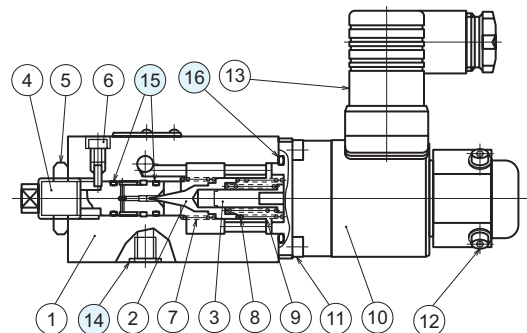
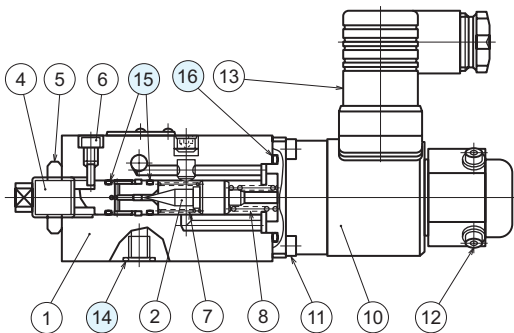

Sealing part table

Part No.	Name	Quantity	Part specifications
14	O-ring	2	JIS B 2401 1B P9
15	O-ring	2	AS568-011 (NBR, Hs90)
16	O-ring	1	AS568-121 (NBR, Hs90)